

Alternating Current-Driven Strain-gage Bridge Amplifier System for Brushless Motors Torque Measurement

Nina Jetchkova Djermanova, Marin Berov Marinov and Borislav Todorov Ganev

Abstract – An alternating current (AC) driven strain gage bridge amplifier system is developed for torque measurement in a brushless motor test bench. AC excitation of the strain gage bridge is applied instead of commonly used DC voltage, and an AC-signal conditioning dual-phase lock-in amplifier is developed using AD630 balanced modulator-demodulator for synchronous detection together with three-pole active Butterworth filter. Thus, lower levels of excitation voltage and lower self-heating of the strain gages are achieved allowing for measurements in very low ranges with high resolution (of about 0.1microstrain/0.05 μ V/V). The measurement system is controlled in a LabVIEW programming environment through high resolution data acquisition (DAQ) system. Additionally, in the test bench the angular velocity of the mechanical shaft and electrical power data are measured. So the mechanical power data can be compared in real time with the energy consumption and other significant variables. Using this “Power Efficiency” information a number of optimization problems can be solved.

Keywords – Brushless motors, Torque measurement, Lock-In amplifier, Power measurement, LabVIEW.

I. INTRODUCTION

The use of mechanical systems driven by electric motors in different production and transportation processes accounts for over two thirds of the electricity consumed by industry [1]. Brushless motors offer several advantages over brushed DC motors, including high torque to weight ratio, more torque per watt (increased efficiency), increased reliability, reduced noise, longer lifetime (no brush and commutator erosion), elimination of ionizing sparks from the commutator, and overall reduction of electromagnetic interference [2]. Because of their high power density, good speed-torque characteristics, high efficiency and wide speed ranges at low maintenance costs brushless motors are widely used in industrial applications where high efficiency in converting electrical into mechanical energy is aimed at. Measuring the torque of these motors is one of the tasks performed on a diagnostics bench when efficiency and power losses have to be evaluated.

N. J. Djermanova is with the Sofia University, Faculty of Physics, 1164 Sofia, 5, J. Bourchier Blvd., e-mail: ninadj@phys.uni-sofia.bg

M. B. Marinov is with the Department of Electronics and Electronics Technologies, Faculty of Electronic Engineering and Technologies, Technical University - Sofia, 8, Kliment Ohridski Blvd., 1756 Sofia, Bulgaria, e-mail: mbm@tu-sofia.bg

B. T. Ganev is with the Department of Electronics and Electronics Technologies, Faculty of Electronic Engineering and Technologies, Technical University - Sofia, 8, Kliment Ohridski Blvd., 1000 Sofia, Bulgaria, e-mail: b_ganev@tu-sofia.bg

The development of modern industry requires more precise tools for test and measurement. This trend is reinforced by the ever stricter legal requirements for low pollutant emissions. Reliable and reproducible detection of relevant measurement variables is becoming increasingly important. A key part of all these studies and optimizations, particularly in the development of engines and transmissions, is the measure of torque, which together with the rotation speed is a measure of (mechanical) power. The processes are dynamic and the interplay of the units such as the engine and transmission is increasingly becoming the focus of optimization [3].

II. TORQUE AND MECHANICAL POWER MEASUREMENT

Torque, being an important factor in the performance of production machines, is measured so that equipment failure is identified and critical situations in important production processes are prevented. A moment is called a torque if its axis corresponds to the axis of rotation defined by the design of the machine concerned. In the case of the moment that results from the action of a single force when the axis of rotation is defined, the computation includes not only the length of the lever arm but also the angle between the lever arm and the force.

For torque measurements, there are numerous applications in the fields of testing technology, operational and process monitoring, automation technology, quality assurance, and research and development. The measurement of true mechanical torque and power on rotating shafts allows users to optimize energy efficiency by first verifying the true power output of the motor(s) and then comparing the energy consumption to motor power output. The precise measurement of torques of rotating parts in particular, is a serious challenge for test equipment manufacturers and users. The current trend is towards looking for opportunities to improve mechanical power and performance by increasing the rotation speed.

There are basically two different approaches of determining the torque: the direct and the indirect method.

A. Direct measurement the torque action

In this method the torque is detected in the rotating strand. Often the term in-line torque measurement is used. Figure 1 shows the principle of action torque measurement. The classic product groups are torque transducers, hubs and flanges [3].

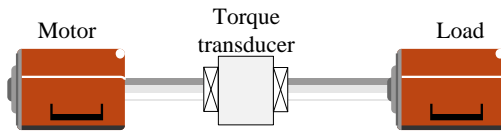

Fig. 1. Measuring the torque action [3].

B. Measuring the reaction force on the lever arm

The method of reaction force measurement, according to the principle action torque is equal reaction torque, is very often used for power determination. The acting at the end of the lever arm force is measured by a load cell. If there is a transmission between the transducer and the point of the powertrain, where the torque is to be actually detected, the transmission ratio must be taken into account by the choice of measuring range and the scaling of the measuring amplifier

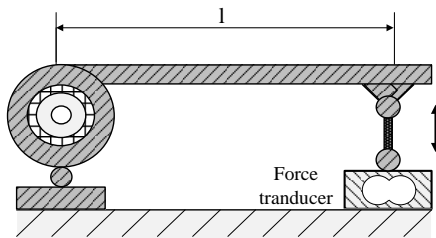

Fig. 2. Measurement of the reaction force with strain gauges (SG).

Today the most common way is to measure the deformation with strain gauges (SG) where their change in resistance is a measure of the strain. Torque sensors consist of main elements spring body with strain gauges and compensation elements, as well as adaptation parts for torque introduction and outtake (Fig. 2) [4, 5].

The techniques widely used for torque measurement apply full Wheatstone strain-gage bridge with an appropriate signal conditioning. Stability, accuracy and high resolution are among the major instrumentation requirements when making motor diagnostics and measurement. Usually a DC voltage is used to power the Wheatstone strain-gage bridge, with a precision instrumentation amplifier connected to the bridge output. High CMRR and low-noise input voltage are must features of the amplifier when striving for high resolution at low strain deviation. Offset drift, 1/f noise, and line noise often impede the measurement of DC signals, hence high precision cannot be achieved [6, 7]. One solution is to use an AC signal to excite the bridge. A bridge amplifier is essentially a simple lock-in, referenced at the AC-bridge frequency (AD 630) [8]. On the other hand, AC methods even though they are not affected by low-frequency noise, drift, and thermal effects, suffer from parasitic reactances – inductive or capacitive [9, 10]. In this paper, a circuit solution is proposed based on the use of a second unloaded (dummy) AC strain-gage bridge, completely identical with the loaded AC bridge. Both strain-gage bridges are mounted closely to each other so that they experience quite equal parasitic effects. The outputs of both amplifiers are subtracted to eliminate the effects of reactances on the result. Thus, at frequencies between 1 kHz and 10 kHz very high sensitivity can be achieved, allowing for measurement of low strain deviations with high resolution.

The power P of a rotating shaft is obtained from the product of torque M_D and angular velocity Ω :

$$P = M_D \Omega. \quad (1)$$

Due to different losses such as friction, atmospheric resistance and heating every machine consumes more power than it delivers. The ratio of the output power P_{OUT} to the input power P_{IN} is known as efficiency coefficient η . In the case of the electrical brushless motors P_{OUT} corresponds to the output mechanical power P_{MECH} and P_{IN} to the input electrical power P_{EL} :

$$\eta = \frac{P_{OUT}}{P_{IN}} = \frac{P_{MECH}}{P_{EL}}. \quad (2)$$

III. MEASUREMENT SET-UP

An instrumentation system in a LabVIEW programming environment is used to control the measurement with a DAQ module that integrates connectivity and signal conditioning and delivers fast and accurate measurements. AC square-wave voltage with a frequency between 1kHz and 10 kHz is generated by DAQ to supply both strain-gage bridges with an rms value of 1, 2 or 5 Volts. Both bridges are full 4-arm strain-gage with nominal resistance of 350 Ohms. Two equally designed lock-in amplifiers are connected to the AC outputs of the bridges. So the first lock-in measures the loaded AC bridge together with the parasitic components, while the second lock-in measures only the effects of the same parasitic components. Subtracting the respective signals measured from loaded and unloaded (dummy) strain-gage bridges is carried out by DAQ system and the final result is displayed on PC.

The proposed measurement set-up with two AC- strain-gage bridges is shown on Fig. 3.

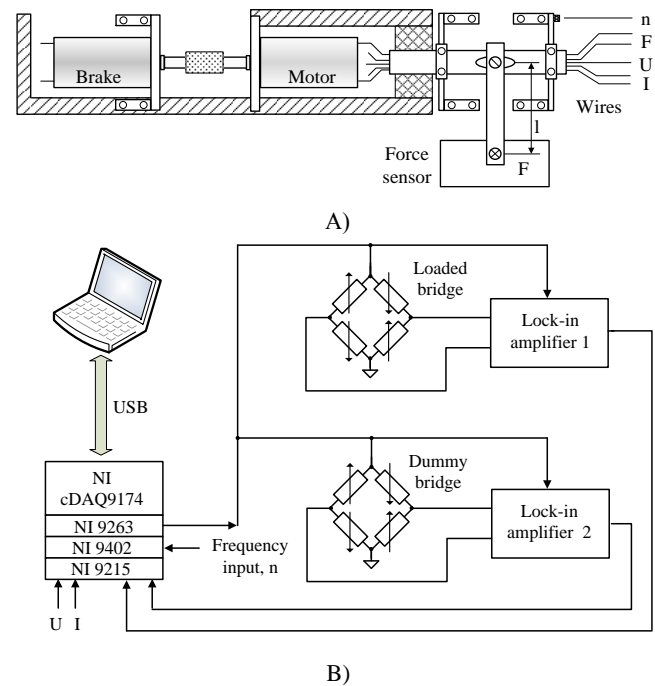

Fig. 3. A) Main components of the test bench. B) Proposed measurement set-up with two AC- strain-gage bridges in LabVIEW environment.

The NI cDAQ-9174 is a 4-slot NI CompactDAQ USB chassis. It has four 32-bit general-purpose counter/timers built in. Each timer can be accessed through NI 9402. The NI 9402 is a 4-channel bidirectional digital input module.

The NI USB-9215A DAQ module offers four channels of simultaneously sampled voltage inputs with 16-bit accuracy. Two channels are used for the measurement of the output signals of the lock-in amplifiers and the other two for electrical power measurement.

NI 9263 is a 4-channel, high-performance analog output 100 kS/s simultaneously updating analog output module. It is used to generate the needed waveforms.

The current measurement uses a precision of 0,01 Ohm (resistance tolerances of 0,5%) 4 terminal Powertron shunt resistor type FPR 4-3316.

For the rotation speed measurement a Texas Instruments DRV5023 digital-switch Hall sensor is used. The device is a chopper-stabilized Hall sensor with a digital latched output for magnetic sensing applications.

IV. AC-STRAIN-GAGE BRIDGE WITH LOCK-IN AMPLIFIER

The main idea of using the AC excitation of the strain-gage bridge is to employ a lock-In amplifier in order to recover the weak bridge signals from the noise. The lock-in amplifier measures the magnitude of a signal in a very narrow frequency bandwidth, while rejects all the components of the signal that are outside it. The lock-in approach has revealed to be better than a simple filtering operation, thanks to its superior performance. In fact, because of the automatic tracking, lock-in amplifiers can give effective quality factor Q values (a measure of filter selectivity) over 100,000, whereas a normal band-pass filter becomes difficult to use with a Q greater than 50 [11].

Here, a simple dual phase lock-in amplifier solution is presented, designed with two AD630 balanced modulator/demodulator circuits. Considering first the way AD630 works, one should discuss the square-wave form of multiplier switching. Using Fourier's theorem, any input signal, including the noise accompanying it, can be represented as the sum of many sine-waves of different amplitudes, phases and frequencies. Let us suppose for example a 2 volt peak-to-peak square-wave at frequency f , which according to Fourier's theorem can be expressed as:

$$V = \frac{4}{\pi} \sin \omega t + \frac{4}{3\pi} \sin 3\omega t + \frac{4}{5\pi} \sin 5\omega t. \quad (3)$$

The phase-sensitive detector in the lock-in amplifier multiplies all these components by a signal at the reference frequency [12]. In the case of the square-wave responding Analog Devices chip AD630, an output proportional to the components of the input signal in phase lock with the reference signal and its odd harmonics has to be expected. Using a three-pole Butterworth low-pass filter one can remove the odd harmonics from the output and obtain a DC signal proportional to the desired signal from the bridge with locked first harmonic frequency.

The second consideration when developing the AC bridge amplifier system is to use dual-phase lock-in amplifier – employing two quadrature phase detectors to

eliminate the effect of phase shift of the signal due to parasitic stray capacitances and wires [13]. An advantage of the dual-phase unit is that if the signal channel phase changes (but not its amplitude) then although the output – “X” – from one detector will decrease, that from the second – “Y” – will increase. It can be shown, however, that the vector magnitude, R, remains constant.

Using DAQ in LabVIEW environment makes the development of dual-phase lock-in amplifier system easy. This DAQ module allows us not only to convert the analog signal into digital, but also to perform mathematical operations over the measured signal. Thus, a simple dual-phase lock-in amplifier has been developed for measuring output from AC strain-gage bridge with two equally performing circuits AD630. The first one multiplies the output signal from the bridge with the reference signal in phase, while the second one multiplies the same signal with the reference signal phase-shifted by 90 degrees. Both AD630 circuits are followed by equally designed three-pole Butterworth filter for eliminating odd harmonics and fed to analog-to digital converter inputs of DAQ. The first output is being referred to as the “X”, and the second output as “Y”

Hence, if the lock-in amplifier is set to display R, changes in the signal phase will not affect the reading and the instrument does not require the adjustment of the reference phase-shifter circuit.

$$R = \sqrt{X^2 + Y^2}. \quad (4)$$

Figure 4 illustrates the circuit diagram of the dual-phase lock-in amplifier system for measurement of the AC strain-gage bridge output.

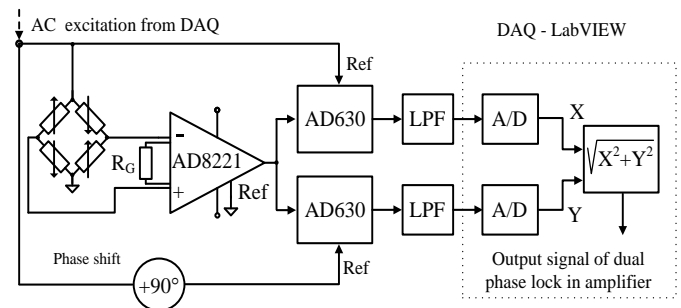

Fig. 4. Dual-phase lock-in amplifier for measuring output from AC strain-gage bridge (AD630)

Here an instrumentation amplifier AD8221 is used directly at bridge output to amplify the weak signals from the strain-gage. The AD8221 is well suited for this application because its high CMRR over frequency ensures that the signal, which is of interest for us and appears as a small difference voltage riding on a large AC common-mode voltage, is picked up and the common-mode signal is rejected. In typical instrumentation amplifiers, CMRR falls off at about 200 Hz. In contrast, the AD8221 continues to reject common-mode signals beyond 10 kHz [14].

V. EXPERIMENTAL RESULTS

TABLE 1 shows the results of the accuracies achieved by DC and AC bridge excitation. For a better comparison of

the results the relative standard deviation (RSD – relation of the standard deviation against the arithmetic mean value in percentage) is used.

TABLE 1. COMPARISON OF THE RELATIVE STANDARD DEVIATION (RSD) BY DC AND AC BRIDGE EXCITATION.

	Force, N	RSD, DC excitation, %	RSD, AC excitation, %	Ratio
1	20	0,8412	0,0624	13,48
2	50	0,6855	0,0519	12,81
3	100	0,4164	0,0364	10,68
4	200	0,2757	0,0192	14,36
5	500	0,1939	0,0116	16,74

The results show the superiority of the proposed AC bridge excitation and lock-in amplifier approach.

TABLE 2 displays the experimental results for the comparison of the relative standard deviation (RSD) by AC bridge excitation in setups with one and two bridges. It can be seen that the measurement setup with 2 bridges outperforms the one bridge setup by 2 – 3 times.

TABLE 2. COMPARISON OF THE RELATIVE STANDARD DEVIATION (RSD) BY AC BRIDGE EXCITATION WITH ONE AND TWO BRIDGES.

	Force, N	RSD, one bridge AC, %	RSD, two bridges AC, %	Ratio
1	20	0,0604	0,0182	3,32
2	50	0,0519	0,0167	3,11
3	100	0,0364	0,0152	2,4
4	200	0,0182	0,0078	2,33
5	500	0,0116	0,0055	2,1

The system displays the values of all parameters, needed for the measurement of electrical and mechanical power and the calculation of the efficiency coefficient in real time. Fig. 5. shows the experimentally obtained dependence between current and efficiency coefficient η .

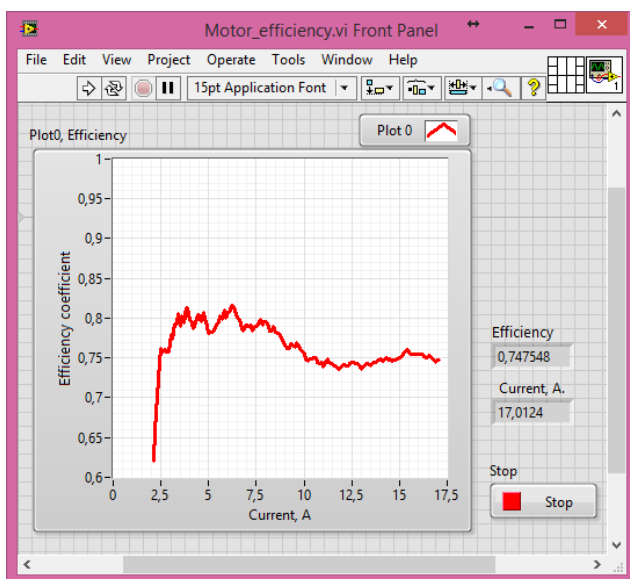

Fig. 5. The experimentally obtained dependence between current and efficiency coefficient η .

VI. CONCLUSION

Torque measurement and control is essential for companies to ensure their product's quality, safety and reliability. This paper presents the implementation of systems for monitoring torque, efficiency and speed of brushless motors. The proposed solution is robust and offers possibilities for significant error reduction. Our framework can easily be augmented by additional sensors if necessary.

The strain gage technique will be the primary solution for torque sensors in the future. As electronics is becoming smaller and electrically more stable, sensors can be designed for higher spring rates which leads to improved dynamics of the measurement. The usage of AC excitation and lock-in amplifier techniques allows the precise amplification of smallest measurement signals. This improved measurement signal conditioning can be successfully used for achieving a higher accuracy of the testing equipment.

REFERENCES

- [1] S. H. Leung, Ed., Intelligent Environmental Sensing, Cham Heidelberg, New, York, Dordrecht, London: Springer, 2015.
- [2] C. Xia, Permanent Magnet Brushless DC Motor Drives and Controls, John Wiley & Sons, 2012.
- [3] R. Schicker, G.Wegener, Drehmoment richtig messen, Hottinger Baldwin Messtechnik GmbH, 2002.
- [4] J. Niebuhr, G. Lindner, Physikalische Messtechnik mit Sensoren, 5 Hrsg., Oldenbourg Wissenschaftsverlag, 2001.
- [5] Ramon Pallas-Areny, John G. Webster, Sensors and signal conditioning, 2nd ed., John Wiley & Sons, 2001.
- [6] Micro-Measurements, "Strain Gage Instrumentation," [Online]. Available: <http://www.vishaypg.com/micro-measurements/>. [Accessed 2015].
- [7] National Instruments, "Measuring Strain with Strain Gages," [Online]. Available: <http://www.ni.com/white-paper/3642/en>. [Accessed 2015].
- [8] Analog Devices, "AD630 Balanced Modulator Demodulator. Data sheets".
- [9] H. Sunaga, M. Kono, T. Taura et al., "High-Precision Strain Measurement Bridge Circuit With Calibration of Parasitic Capacitance Effects," in Technical Meeting on Electronic Circuits, IEEJ, ECT-06-28, Kiryu, March 2006.
- [10] T.Taura, M.Kono, H.Sunaga et al., "High-Precision Strain Measurement Bridge Circuit Systems," in The 23th Sensing Forum, The Society of Instrument and Control Engineers, Oct. 2006.
- [11] A. De Marcellis, G. Ferri, Analog Circuits and Systems for Voltage-Mode and Current-Mode Sensor Interfacing Applications, Heidelberg: Springer, 2011.
- [12] P. Elmer, "TN 1002: Specifying a Lock-In Amplifier," 2000.
- [13] M.Kono, T. Taura, H. Sunaga et al., "A High-Precision AC Wheatstone Bridge Strain Gauge," [Online]. Available: <http://www.el.gunma.ac.jp/~kobaweb/news/pdf/P06003.pdf>. [Accessed 2015].
- [14] Analog Devices, "AD8221 Instrumentation amplifier. Data sheets".