

Time Signal Based Warping Algorithms for Low Speed Velocity Estimation of Rail Vehicles

Stefan Hensel and Marin Berov Marinov

Abstract – The precise determination of the velocity of rail vehicles is fundamental for the use of modern train control systems and logistics. Eddy current sensor systems allow for a slipless estimation of the velocity based on cross-correlation techniques. Those suffer in precision when driving with very low velocity or in area with high accelerations. This paper presents an alternative estimation of the velocity in these time intervals by employing correlation optimized warping, a variant of the dynamic time warping algorithms widely used for example in speech recognition..

Keywords – Velocity Estimation, Correlation, Dynamic Programming, Eddy Current Sensor

I. INTRODUCTION

The reliable and precise determination of the velocity of a rail vehicle is crucial for any further tasks such as efficient logistics or the employment of modern train disposition systems to raise the amount goods transported on existing tracks [1]. Actual systems are built upon common velocity sensors like GNSS or radar systems that face problems when dealing with heavy environment conditions or shadowed areas like stations or dense forests [2]. In contrast, an eddy current sensor system provides non-contact speed and distance measurement of rail vehicles by measuring the magnetic inhomogeneities along the track and utilizes the cross-correlation technique to determine the time shift between the two sensors mounted within the housing [3]. The sensor works well and robustly especially at higher velocities. Nonetheless, this type of sensor encounters difficulties in phases of high de- and acceleration as well as in passages with very low speed maneuvers, e.g. when driving over turnouts in railway stations. This paper outlines a signal processing approach to overcome this problems in lower velocities based on so called warping algorithms, an specific application of the dynamic programming [4]. In particular, two types of algorithm are examined. On the one hand the classical *dynamic time warping* (DTW) [5] and on the other an adapted variant, the so called *correlation optimized warping* (COW) [6] are compared against the classical cross-correlation approach, based on a closed-loop correlator [7]. The warping algorithms are commonly employed for the task of sequence classification, where they are capable of distorting one sequence by stretching it compared to a class template. This paper makes use of this signal straining as it is directly proportional to the difference of the two signals determined by cross

S. Hensel is with the Department of Measurement and Control Systems, Faculty of Mechanical Engineering, Karlsruhe Institute of Technology, Karlsruhe, Germany, e-mail: shensel@kit.edu

M. Marinov is with the Department of Electronics and Electronics Technologies, Faculty of Electronic Engineering and Technologies, Technical University - Sofia, 8, Kliment Ohridski Blvd., 1000 Sofia, Bulgaria, e-mail: mmbm@tu-sofia.bg

correlation. Fig. 1 gives a system overview. As long as the rail vehicle stays below a certain velocity, the speed is determined via the two warping algorithms.

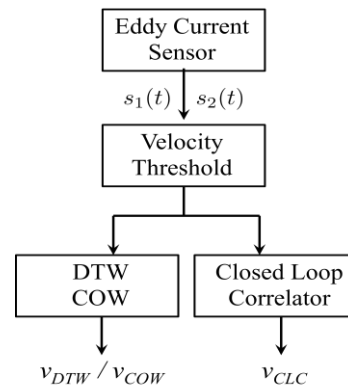

Fig. 1. System overview of the presented algorithms. A velocity threshold determines if either the common closed loop correlator or the warping algorithms are used for velocity estimation.

After driving faster, commonly on open tracks, the common closed loop correlator (CLC) is employed for estimation.

The paper is organized as follows: Chapter II introduces the eddy current sensor system and its working principle. It also explains the commonly used cross-correlation realized with a CLC. Afterwards, chapter III introduces the concept of time warping algorithms and explains the two algorithms as well as how to use them for velocity estimation. Chapter IV principally shows the applicability of the algorithms and evaluates them by using simulated data. Chapter V proves the capability on real signals before chapter VI concludes the paper with a summary.

II. EDDY CURRENT SENSOR SYSTEM

A. Working principle and sensor system

Eddy current sensors (ECS) are commonly used to detect inhomogeneities in the magnetic resistance of ferromagnetic materials [8]. This basic approach has further been developed and adopted to possible applications on railway vehicles, including speed measurement and pattern recognition tasks. The ECS system consists of two identical sensor devices, each built up with a transceiver coil and two pickup coils. Both sensors are sequentially placed within a housing that is mounted on the train bogie approximately 10 cm above the rail head. Fig. 2 (a) depicts the principle of an ECS with a single unit: The transmitter coil E excites a magnetic field H_E that induces eddy currents in metallic materials like the rail. The eddy currents induce an antipode magnetic field H_{EC} , that generates the voltage $u_{p1}(t)$ and $u_{p2}(t)$ within

the pick-up coils $P1$ and $P2$ respectively. By interconnecting them differentially, the output signal $u_{P1}(t) - u_{P2}(t)$ is a measure for rail inhomogeneities. These mainly result from rail clamps, turnouts and other irregularities, e.g. cracks or signal cables (for details see [3]).

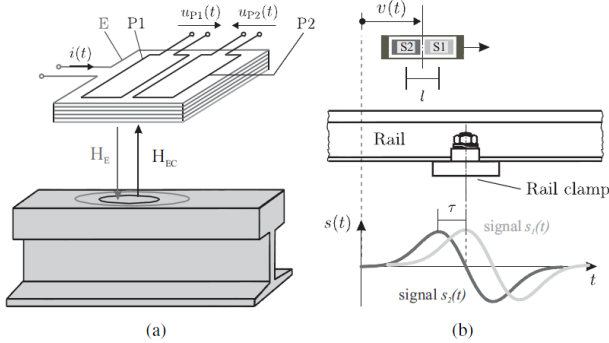

Fig. 2. (a) Single ECS S1, (b) Example signal of ECS system (two sensors) $s(t)$ when crossing a rail clamp.

The signals $s_1(t)$ and $s_2(t)$ represent a stochastic process. Clamps produce a stationary process for rail vehicles driving on open tracks with constant velocity. Turnouts, cables, and metallic clutter represent non-stationary signal components, whereas both parts are superimposed by a noise process that can be regarded as zero mean white Gaussian noise. The overall signal comprises a high signal-to-noise ratio (SNR), given that pre-processing low pass filters are installed in the sensor hardware.

B. Correlation Based Velocity Estimation

The described working principle is, in contrast to vision based systems or Doppler principle based radar sensors, widely unsusceptible to environmental perturbations and, because of the differential setup, robust against systematic influences. These properties are highly desirable for a reliable speed measurement under rough railway conditions.

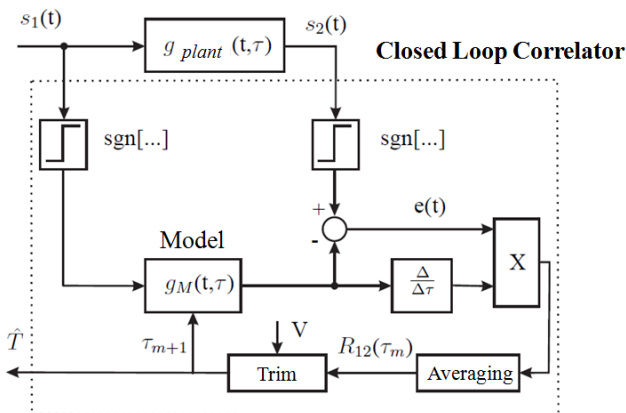

Fig. 3. Working principle of the described CLC. The polarity based approach corresponds to an iterative Newton-Raphson minimization.

Velocity estimation can commonly be achieved via cross-correlation of the two sensor signals $s_1(t)$ and $s_2(t)$, that are idealized depicted in fig. 2. (b). First approaches, intended and optimized for hardware realization, apply a CLC assuming a known sensor distance l and a measured time difference Δt . In contrast to open loop systems, the CLC tracks the time shift τ between the signals by building a control loop and setting the derivative to zero. The latter is achieved by a modified Newton-Raphson scheme. The hardware is commonly realized with a polarity correlator for easy realization. Details on setup and working principles of CLCs can be found in [7].

III. VELOCITY ESTIMATION WITH COW

The above mentioned approaches rely on the assumption of a stationary stochastic process, which holds for constant velocity within the cross-correlation interval. Whereas this assumption is correct in most situations, it is heavily violated in low speed manoeuvres, where large changes in the relative velocity may occur. This is unfortunately the case in areas of interest, i.e. within stations, where many turnouts are present that additionally disturb the signals. The need for reliable distance estimation in localization scenarios makes it necessary to apply a velocity estimation that can cope with these situations. Therefore, we propose the use of a dynamic programming scheme commonly used in the speech processing, the so called *time warping*.

A. Dynamic Time Warping

Dynamic time warping tries to minimize the distance between to signals $s_1(t)$ and $s_2(t)$ defined with

$$D(s_1(t_i), s_2(t_j)) = \sum_{i=j=1}^n |(s_1(t_i) - s_2(t_j))| = \sum_{i=j=1}^n d[i, j] \quad (1)$$

by duplicating the indices of the target signal. This is done under the constraints, that start and endpoints of both signals are identical, as well as imposing monotony and continuity. This problem is solved with dynamic programming to ensure computational tractability [4]. Results of DTW are a warped signal and the so called distance matrix that reflects the distortion of the signals at a given time point. An example result for constant velocity and therefore two signals with a constant offset is shown in fig. 4.

B. Correlation Optimized Time Warping (COW)

COW was first described as an adaption of DTW in the field of gas chromatography [6]. In contrast to DTW, COW tries to adjust the two signals piecewise. It separates the signals into segments of length m that can be stretched or compressed. Instead of the distance measure of Equation (1), the signal similarity is based on a cross correlation within the signals. Again, the amount of the distortion of each segment can be determined by the employment of dynamic programming. Therefore the segments may be shifted by x_i which must satisfy the following condition:

$$x_i \pm u_i; [u_i \in (-t, t)] \quad (2)$$

After shifting the segments with a so called *slack* t the shortened signal is compared with the target signal Z by adapting the segment size from $m + t$ to the reference signal size m_Z which is done by a linear interpolation. Afterwards, the signal similarity is determined by cross correlation. The possible segment shifts by the slack and the subsequent comparison of the signals is not feasible even for a small amount of segments. Therefore the problem is again solved by dynamic programming. The derivation of the algorithm is not in the scope of this contribution and can be found in [6] and [9]. An example for simulated data is shown in fig. 5.

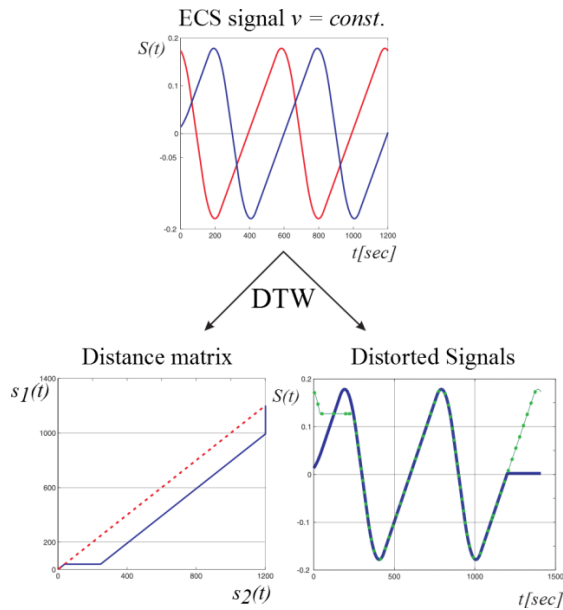

Fig. 4. Exemplary result of DTW. The upper picture shows ECS signals at constant speed. The corresponding distance matrix is shown on the lower left, emphasizing the constant signal offset. The warped signal (dotted line) is shown on the lower right.

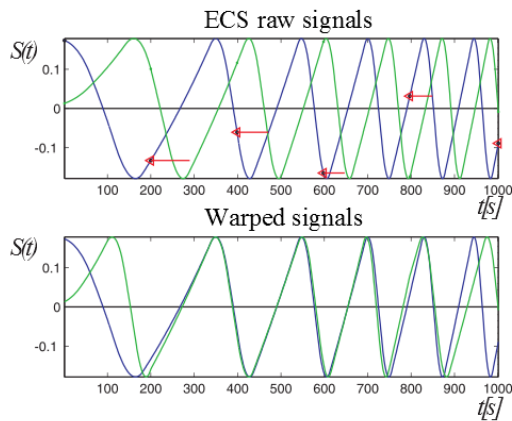

Fig. 5. Exemplary result of COW. The upper half shows simulated eddy current signals with accelerations. The arrows indicate the shift of the individual segments. The lower part shows the warped results.

IV. SIMULATION

A. Simulation Framework

To verify the possibility to determine the shift of the eddy current sensor signals with the warping algorithms, a

simulation was done. Therefore, several velocity profiles were simulated assuming a sleeper distance of 600 mm a sensor distance of 208 mm and a sensor frequency of 1 kHz. Accelerations were restricted to a maximum of 3 m/s^2 which is the maximum achievable braking power of the observed rail vehicles. Afterwards, additive white Gaussian noise was added to simulate real world disturbances. The sequences were commonly chosen to have the length of 1-2 seconds which corresponds to the common correlator length. Exemplary velocity profiles and their respective noise free signals are shown in fig. 6.

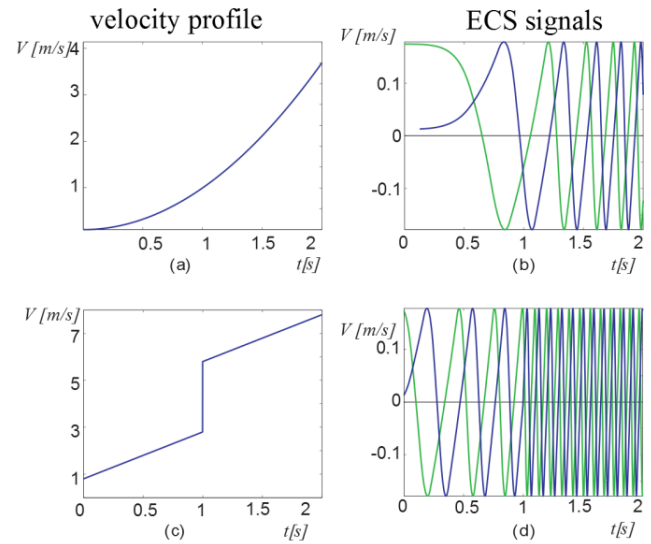

Fig. 6. Simulated ECS signals. (a) and (c) show exemplary velocity profiles, (b) and (d) show the corresponding signals of the two sensor coils without additive noise.

B. Simulation Results

All algorithms, DTW, COW as well as the CLC were used to determine the velocity profile within the given signal periods. Results for the DTW are depicted in fig. 7.

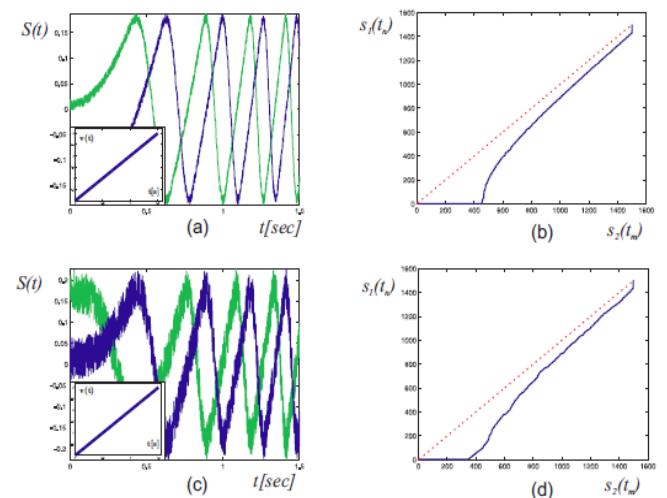

Fig. 7. Simulative results for DTW. The left side part depicts input and warped signals; the right side part shows the estimated velocity.

Fig. 8 shows the results for the COW which is capable to determine the velocity precisely.

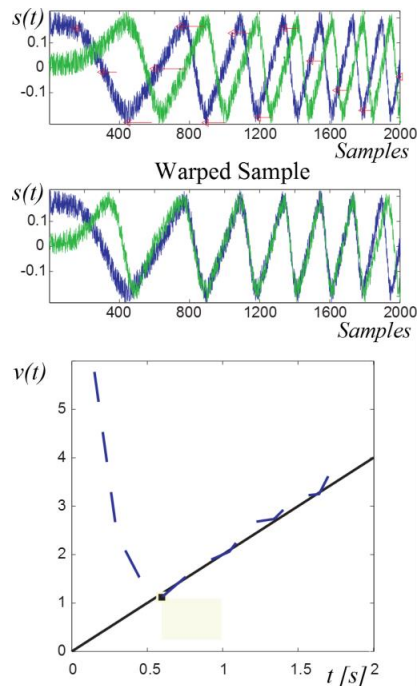

Fig. 8. Simulative results for COW. The upper half depicts input and warped signals; the lower half shows the estimated velocity in the segments as dotted line, the correct profile is the solid line.

V. EXPERIMENTAL RESULTS

The same algorithms were used for real world data acquired on test drives with a tram. Fig. 9 shows the results for a sequence for a train starting within a train station.

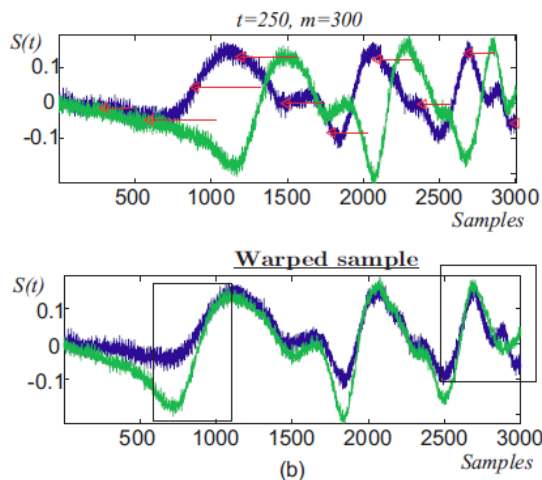

Fig. 9. Results for the warping of real data. The signals below are aligned correctly by the COW.

The signals could be recovered well by the COW whereas the simple DTW was not capable to determine the correct velocity as in the simulation. This is mainly due to the fact that, in contrast to the correlation based quality measure, noise is not handled as well. The results of the three algorithms are qualitatively compared in Table 1.

TABLE 1. QUALITATIVE COMPARISON FOR REAL WORLD DATA

	Complexity of computation	Robustness against noise	Precision $v = \text{const} / \neq \text{const}$
CLC	++	+	+ / -
DTW	-	--	- / --
COW	--	+	+ / +

The results indicate that COW is an alternative to the common CLC based velocity estimation especially in low velocity manoeuvres. A drawback is the high computational complexity. It cannot be estimated in advance and reaches up to several seconds even for small sequences. This makes them less capable for real systems than model based approaches recently presented in [10].

VI. CONCLUSION

The contribution proposes a novel approach to determine the signal shift of eddy current sensor signals for the purpose of velocity estimation. Whereas the common DTW is not capable to handle real world data due to noise, the presented COW deals well even with severely stretched signals. A drawback of the method is the high computational load that prevents an implementation on embedded systems.

REFERENCES

- [1] P. Winter, J. Braband, and P. de Cicco, "Compendium on ERTMS: European Rail Traffic Management System," UIC International, 2009.
- [2] F. Böhringer, "Train location based on fusion of satellite and trainborne sensor data," *Location Services and Navigation Technologies*, vol. 5084, p. 76–85, 2003.
- [3] T. Engelberg and F. Mesch, "Eddy current sensor system for non-contact speed and distance measurement of rail vehicles," *Computers in Railways*, 2000.
- [4] C. Bahlman, *Dynamic Programming*, Princeton University Press, 1957.
- [5] H. Sakoe and S. Chiba, "Dynamic programming algorithm optimization for spoken word recognition," in *IEEE Trans. on Acoustics, Speech and Signal Processing*, 1978.
- [6] G. Tomasi, F. van den Berg, C. Anderson, "Correlation optimized warping an dynamic time warping as preprocessing methods for chromatographic data," *Journal of Chemometrics*, vol. 18, pp. 231-241, 2004.
- [7] H. B. a. H. Moll, "A modified Newton-Raphson-Search for the Model-Adaptive Identifications of Delays," *Identification and System Parameter Estimation*, 1979.
- [8] P. McIntire and R. C. McMaster, *Nondestructive Testing Handbook, Vol. 4*, The American Society for Nondestructive Testing, Columbus, Ohio, 1986.
- [9] N. Nielsen, J. Carstensen, J. Smedsgaard, "Aligning of single and multiple wavelength chromatographic profiles for chemometric data analysis using correlation optimised warping," *Journal of Chromatography A*, vol. A 805, no. 1–2, pp. 17-35, May 1998.
- [10] T. Strauss, C. Hasberg, and S. Hensel, "Correlation based velocity estimation during acceleration phases with application in rail vehicles," in *IEEE/SP 15th Workshop on Statistical Signal Processing*, 2009.